

**The PR1**

# Eletta Liquid Paddle Switch

control of flow or no-flow conditions



**Eletta flow**

when you want to know

# Specifications PR1

## Function

The Eletta PR1 Paddle Switch is using the liquid flow to activate the spring supported paddle and the micro-switch to give an alarm if the flow stops or starts.

PR1 can be used in pipe sizes from DN50 to DN250 and the set point is dependent on the length of the paddle and the pipe size, please refer to the table below.

The installation is simple as you can cut the paddle to the desired length on site according to the actual pipe size. The paddle aligns fully with the flow and creates a very small pressure drop. The function works only in one flow direction. Wetted parts is made of Copper Alloy and Stainless Steel and the sealing of Nitrile (HNBR).

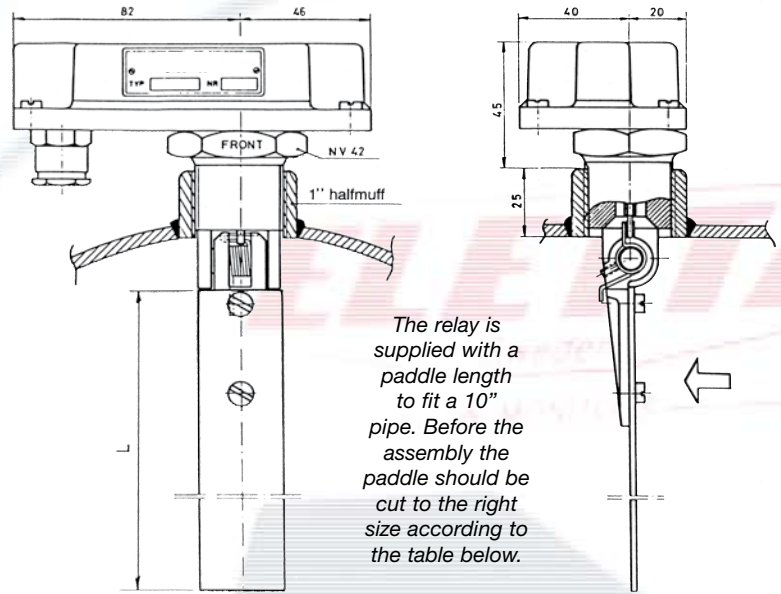

The relay is supplied with a paddle length to fit a 10" pipe. Before the assembly the paddle should be cut to the right size according to the table below.

## Specification

Wetted material	Copper Alloy and 316 SS
Sealing Material	Nitrile (HNBR)
Max. pressure	25 bar
Max. temperature	+125°C (257°F)
Min. temperature	-20°C (-4°F)
Protection class	Standard IP43 Option IP65
Process connection	25 mm thread (1" BSP) (through pipe wall)
Pipe Sizes	DN50–DN250
Switch	Microswitch SPDT 1-pole 2-way
	
Breaking capacity at inductive or resistive load	250 VAC 16 A 24 VDC 1 A 48 VDC 0,2 A 110 VDC 0,02 A

## Max Length Paddle

Pipe sizes	L mm
2"	22
2 1/2"	38
3"	52
4"	75
5"	100
6"	125
8"	175
10"	200

## Mounting

The PR1 is position dependent and can only be mounted in a horizontal pipe with the connection box in an upward position. Please make sure that the flow direction is according to the arrow placed inside the connection box. A straight run free from bends and valves of 3 pipe inner diameter up- and downstream is recommended for proper function.

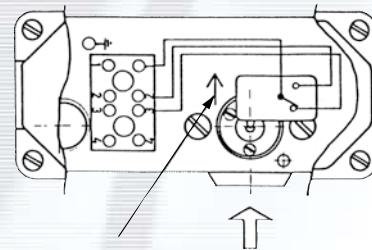

When installing make sure that the flow direction is in accordance with the arrow.

## Function test in water

Dimension	Switch-on value l/min appr.	Switch-off value l/min appr.
DN 50	> 125	< 75
DN 65	> 150	< 100
DN 80	> 200	< 150
DN 100	> 300	< 200
DN 150	> 350	< 250

# ELETTA

— FLOW MONITORS —

**Eletta Flow AB**

Box 5084, SE-141 05 Huddinge, Sweden  
Tel. +46 8 603 07 70 • Fax. + 46 8 646 10 40  
[info@eletta.com](mailto:info@eletta.com) • [www.eletta.com](http://www.eletta.com)